

LV-BAT-R5.12-Aa/Ab



Operation Manual
LV-BAT-R5.12-Aa/Ab Lithium Battery

Contents

1	Product Overview.....	1
1.1	Appearance.....	1
1.1.1	Rack mounted LV-BAT-R5.12-Aa/Ab.....	1
1.1.2	Wall mounted LV-BAT-R5.12-Aa/Ab.....	2
1.1.3	Cabinet mounted LV-BAT-R5.12-Aa/Ab.....	2
1.2	Button,LED & Communication Port.....	3
1.2.1	Switch ON/OFF.....	3
1.2.2	LED Indicator Definition.....	3
1.2.3	RS485/RS232/CAN.....	5
1.2.4	RS232 Port.....	5
2	Installation Guide.....	6
2.1	Checking Deliverables.....	6
2.1.1	Rack mounted accessory deliverables.....	6
2.1.2	Wall mounted accessory deliverables.....	7
2.2	Tools.....	8
2.3	Installation Instructions.....	9
2.3.1	Dimensions.....	9
2.3.2	Installation Steps (Rack Mounted).....	10
2.3.3	Installation Steps (Wall Mounted).....	11
2.3.4	Wiring Steps.....	13

1 Product Overview

LV-BAT-R5.12-Aa/Ab is a 51.2V 100Ah Lithium battery that can be rack mounted, wall mounted or cabinet mounted. **LV-BAT-R5.12-Aa/Ab is not suitable for supporting life-sustaining medical devices.**

1. Appearance

1. Rack mounted LV-BAT-R5.12-Aa/Ab

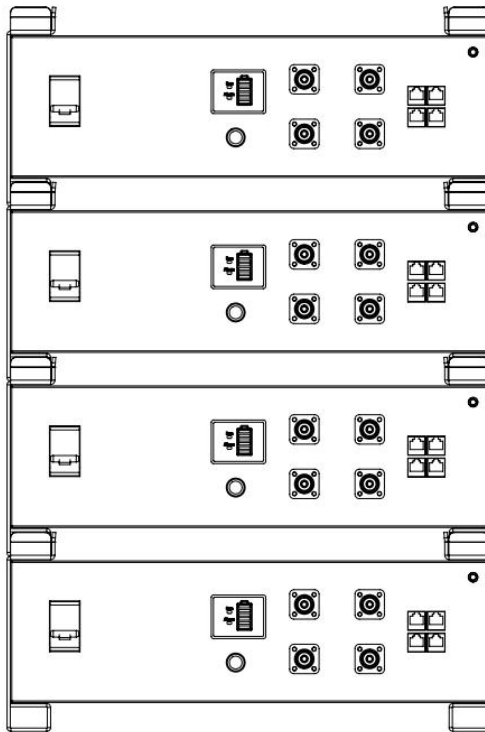

1.1.2 Wall mounted LV-BAT-R5.12-Aa/Ab

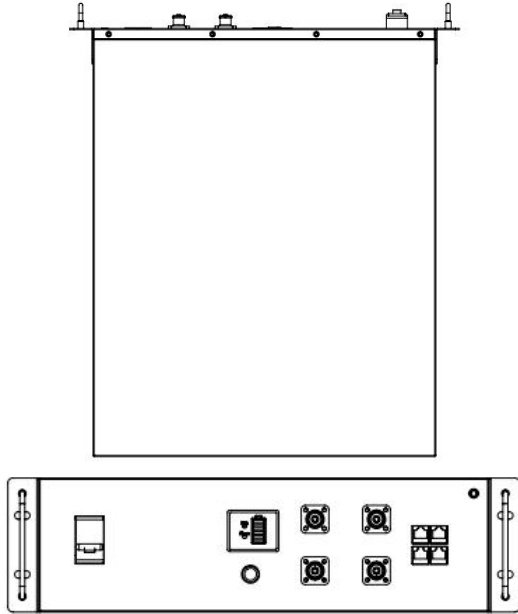

1.1.3 Cabinet mounted LV-BAT-R5.12-Aa/Ab

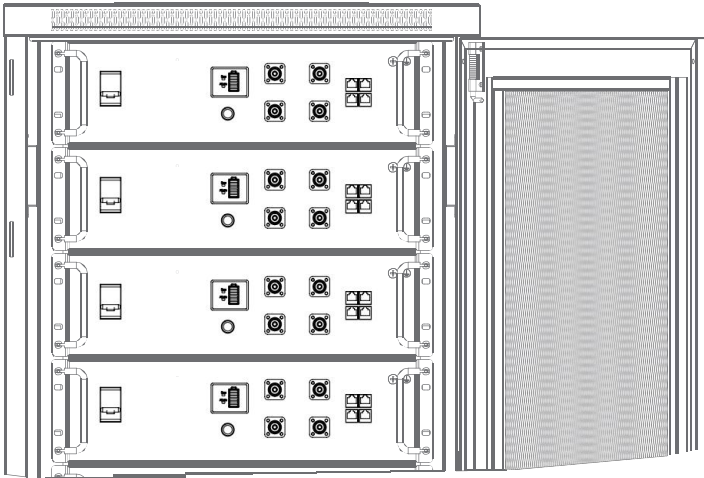

2. Button,LED & Communication Port

1.2.1 Switch ON/OFF

2.1 Switch ON

For single LV-BAT-R5.12-Aa/Ab, switch ON rocker switch ,then long press (more than 3 seconds) ON/OFF button on front panel, LED will flash then battery will operate normally. L1 to L6 shows battery SOC, L7/L8 shows battery status.

For multiple LV-BAT-R5.12-Aa/Ab in parallel, switch ON rocker switch on all batteries, long press (more than 3 seconds) ON/OFF button of MASTER battery, LED will flash, battery system will automatically encode and assign ID to each slave battery, then battery system will operate normally.

2.2 Switch OFF

Press start button of Master PACK more than 3s and then release the button, the master pack will shut down after all slave packs shut down(Sleep mode).

For single LV-BAT-R5.12-Aa/Ab, switch OFF rocker switch.

For multiple LV-BAT-R5.12-Aa/Ab in parallel, switch OFF rocker switch on MASTER battery first. Then switch OFF rocker switch on all slave batteries.

1.2.2 LED Indicator Definition

Note:

flash 1 - 0.25s light / 3.75s off

flash 2 - 0.5s light / 0.5s off

flash 3 - 0.5s light / 1.5s off

LED Indicators Instructions

Status	RUN	ALM	Battery Level Indicator						Descriptions	
	L8	L7	L6	L5	L4	L3	L2	L1		
Shut down	OFF	OFF	OFF	OFF	OFF	OFF	OFF	OFF	All OFF	
Standby	Flash 1	OFF	According to the battery level						Indicates Standby	
Charging	Normal	Light	OFF	According to the battery level						The highest capacity indicator LED flashes(Flash 2),others lighting
	Full Charged	Light	OFF	Light	Light	Light	Light	Light	Light	Turn to standby status when charger off
	Protection	OFF	Light	OFF	OFF	OFF	OFF	OFF	OFF	Stop charging
Discharge	Normal	Flash 3	OFF	According to the battery level						
	UVP	OFF	OFF	OFF	OFF	OFF	OFF	OFF	OFF	Stop charging
	Protection	OFF	Light	OFF	OFF	OFF	OFF	OFF	OFF	Stop discharge
Fault	OFF	Light	OFF	OFF	OFF	OFF	OFF	OFF	Stop charging and Discharge	

Charging Battery Level Indicators Instructions

Status		Charging							
Battery Level Indicator		L8	L7	L6	L5	L4	L3	L2	L1
Battery Level (%)	0~17%	Light	OFF	OFF	OFF	OFF	OFF	OFF	Flash 2
	18~33%			OFF	OFF	OFF	OFF	Flash 2	Light
	34~50%			OFF	OFF	OFF	Flash 2	Light	Light
	51~66%			OFF	OFF	Flash 2	Light	Light	Light
	67~83%			OFF	Flash 2	Light	Light	Light	Light
	84~100%			Flash 2	Light	Light	Light	Light	Light
	Full Charged			Light	Light	Light	Light	Light	Light

Discharging Battery Level Indicators Instructions

Status		Discharge							
Battery Level Indicator		L8	L7	L6	L5	L4	L3	L2	L1
Battery Level (%)	0~17%	Flash 3	OFF	OFF	OFF	OFF	OFF	OFF	Light
	18~33%			OFF	OFF	OFF	OFF	Light	Light
	34~50%			OFF	OFF	OFF	Light	Light	Light
	51~66%			OFF	OFF	Light	Light	Light	Light
	67~83%			OFF	Light	Light	Light	Light	Light
	84~100%			Light	Light	Light	Light	Light	Light

1.2.3 CAN / RS485 Port

CAN / RS485 (RJ45) to PCS

PIN	Definition
Pin 1、Pin 8	RS485-B (to PCS, reserved)
Pin 2、Pin 7	RS485-A (to PCS, reserved)
Pin 3	NC
Pin 4	CANH (to PCS)
Pin 5	CANL (to PCS)
Pin6	GND

1.2.4 RS232 Port

RS232 (RJ45) to PC



PIN	Definition
Pin 8、Pin 1	GND
Pin 2、Pin 7	RS232_TX
Pin 3、Pin 6	RS232_RX
Pin 4、Pin 5	NC



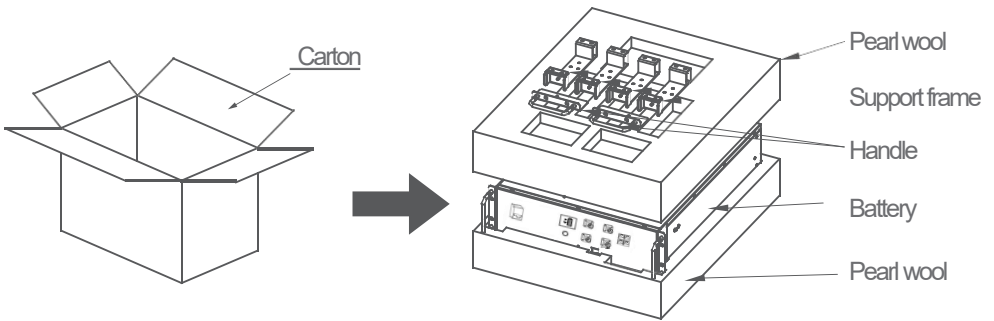

2 Installation Guide

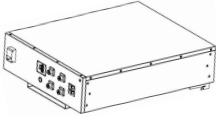
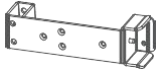
1. Checking Deliverables





1. Rack mounted accessory deliverables





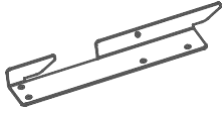





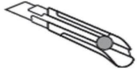

NO.	Pictures	Quantity	Description
1		1PCS	Battery
2		4PCS	Support frame
3		12PCS	M4*8

4		8PCS	M6*50
5		1PCS	Manual
6		1PCS	Test report
7		1PCS	Certificate

2.1.2 Wall mounted accessory deliverables

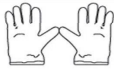
NO.	Pictures	Quantity	Description
1		2PCS	Hanging bracket
2		1PCS	Wall bracket
3		4PCS	M8*60 Expansion bolts
4		2PCS	M4*20
5		10PCS	M6*16

2.2 Tools

Model	Tools		
Installation	Knife 	Measuring tape 	Socket wrench (10/16mm) 
	Rubber mallet 	Cross Screwdriver 	Hammer drill (8mm) 
Protection	ESD gloves 	Safety goggles 	Anti-dust respirator 
	Safety shoes 		

3. Installation Instructions

1. Dimensions

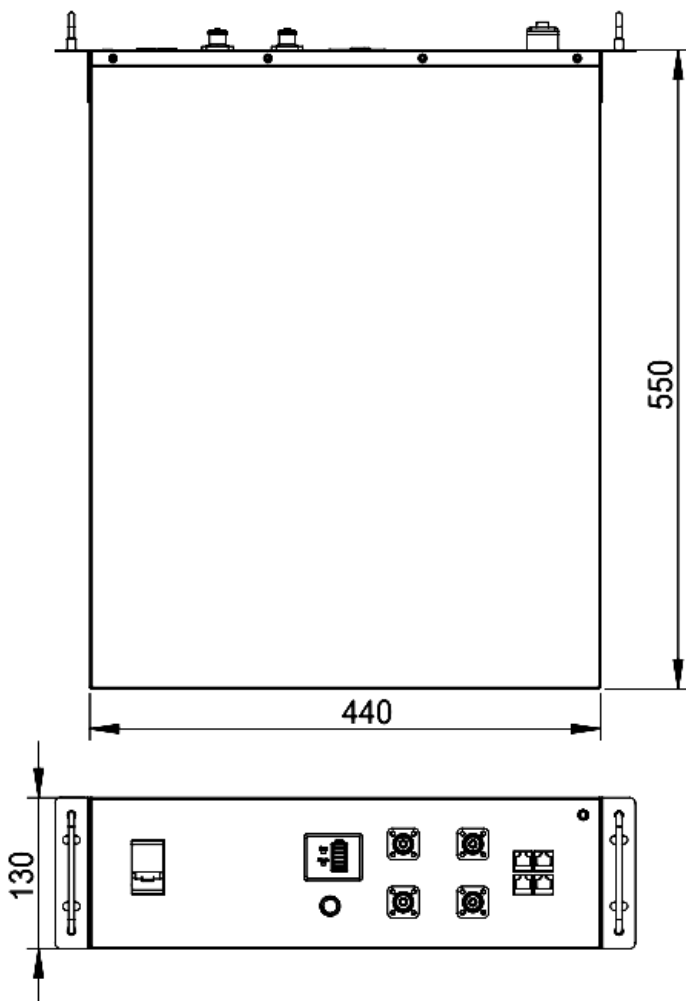

2.3.2 Installation Steps (Rack Mounted)

Step 1

Remove the handle from the battery.

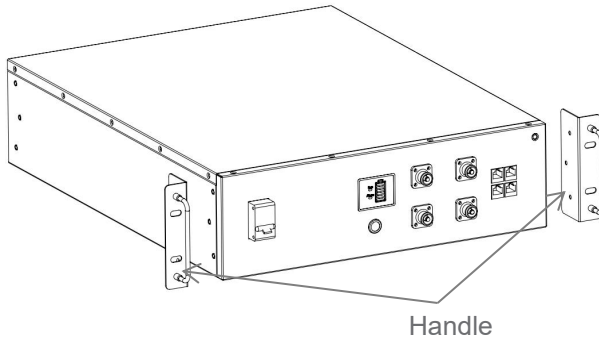

Step 2

Install Support frames at the four corners of the battery.

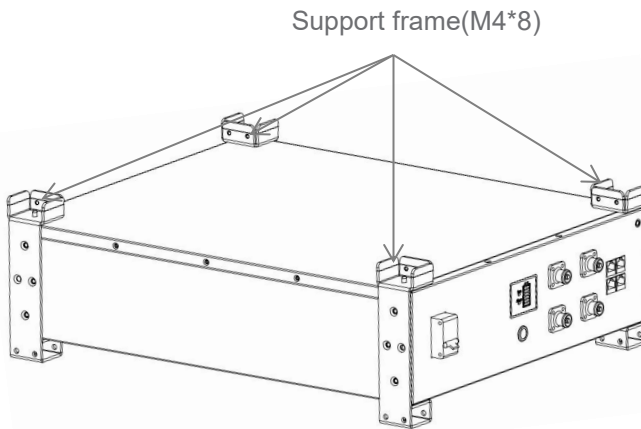

Step 3

The battery with the support frame is stacked up and down.

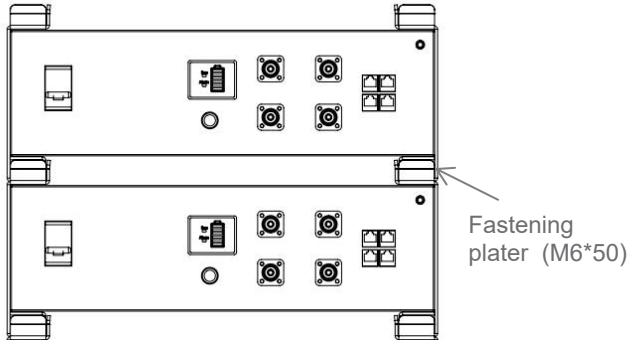

2.3.3 Installation Steps (Wall Mounted)

Minimum mounting distance requirement: (Wall Mounted)

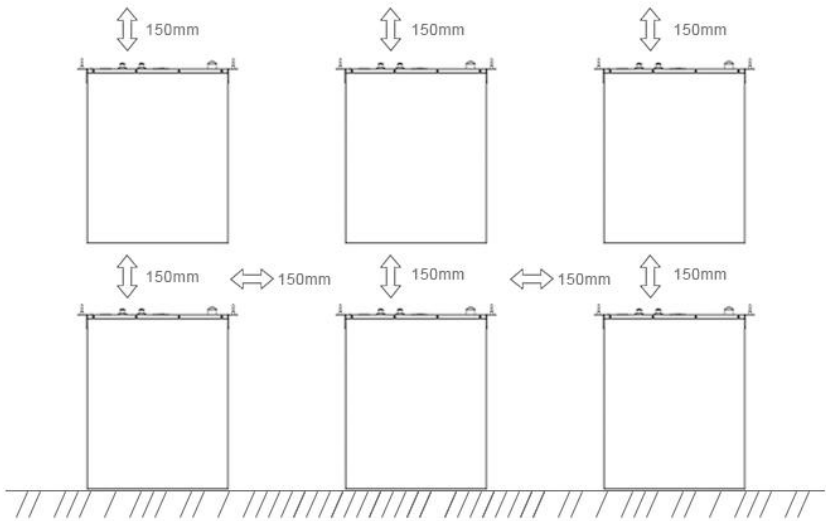

Step 1

Drill the hole with an 10mm drill bit as follows and fix the wall bracket to the wall.

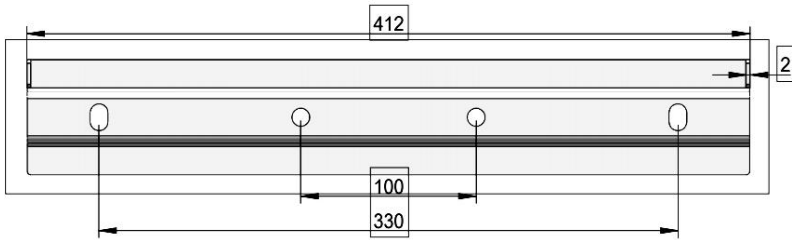
**Step 2**

Install the wall hanging bracket.

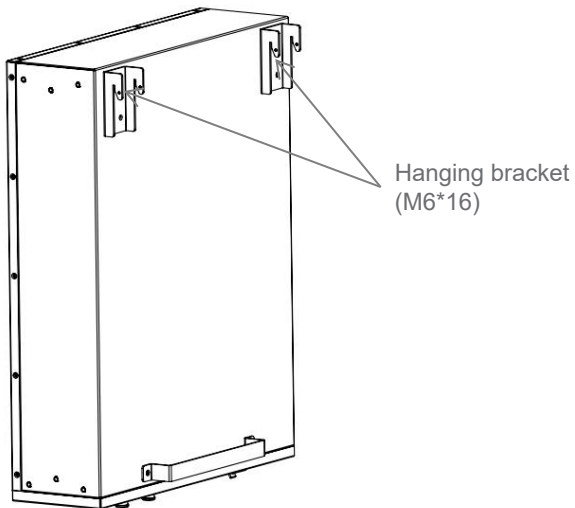

Step 3

Hang the machine on the wall hanging back plate and tighten it.

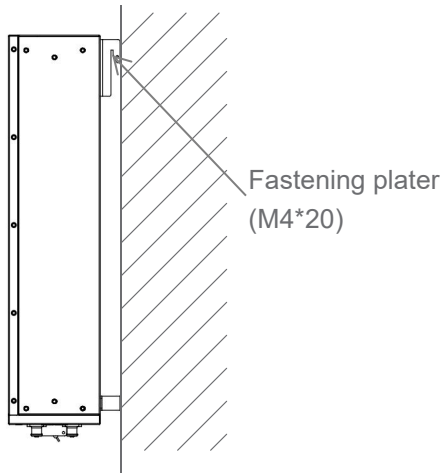

2.3.4 Wiring Steps

Step 1

Connected to ground.

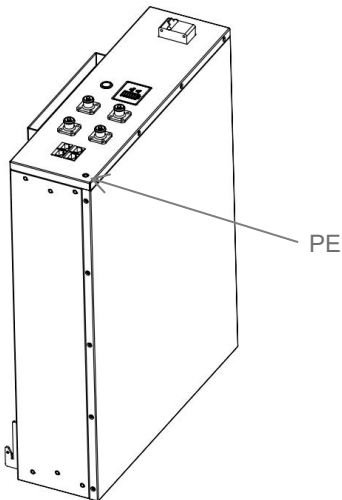

Step 2

Connecting power line.

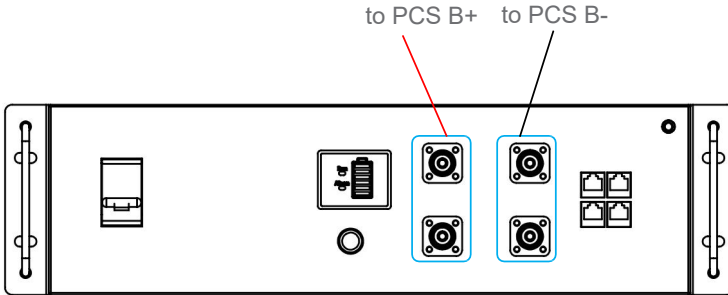
**Step 3**

Connect the communication lines.

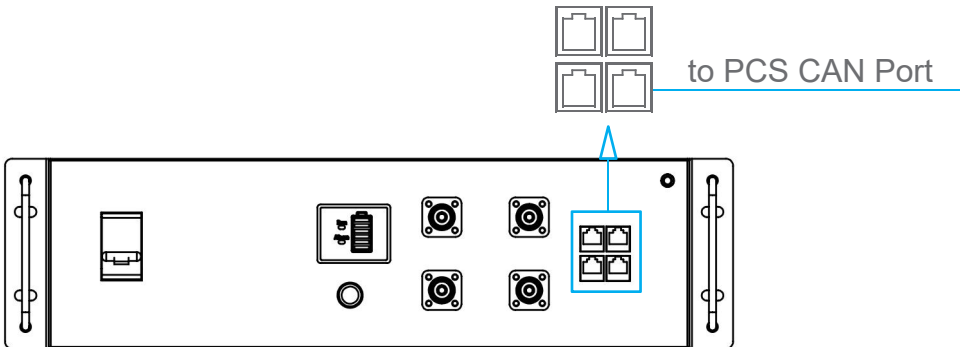

Step 4

When multiple batteries are connected in parallel, follow the following wiring mode.

